



Bobcat®

Mini Track Loaders



One Tough Animal™

One-Man Crew!

Bobcat® Mini Track Loaders

Landscapers...Contractors...Rental Operators...
here's the perfect complement to your loader fleet!

They're tough, versatile, fast, agile and strong! They deliver all the rugged dependability you expect from the Bobcat brand, along with the jobsite convenience of a walk-behind mini track loader!

What can they do?

You name it. The MT52 and MT55 dig, auger, till, trench, move material — and all kinds of other jobs you'll think of when you're out on the worksite.

Either 36 or 42 inches wide

Each mini track loader packs a lot of power in a small package. They let you work in tight spots, both indoors and outdoors, and easily slip through most doorways and fence gates.



Simple to operate

One-hand drive operation makes it the easiest-to-operate mini track loader.



Durability that lasts

Bobcat mini track loaders feature liquid-cooled diesel engines for maximum performance and durability.



Tilt Steering

Adjustable height drive controls ensure operators of varying heights can work comfortably.

Ride on it or walk behind it!

- Hook up or unhook exclusive ride-on platform within seconds
- Pivoting platform provides smooth ride
- Large standing surface area promotes operator comfort
- Platform moves like a wheelbarrow when not installed
- Platform is easy to transport



MT52	520 lb.	71.3 in.	20 hp	36 in.	12 gpm
	Rated Operating Capacity	Lift Height	Liquid-Cooled Diesel Engine	Width (with bucket)	Auxiliary Hydraulic Flow

MT55	550 lb.	71.3 in.	25 hp	36 in.	12 gpm
	Rated Operating Capacity	Lift Height	Liquid-Cooled Diesel Engine	Width (with bucket)	Auxiliary Hydraulic Flow

Get versatile! Hook up to a wide choice of hard-working Bobcat attachments, including:



Angle Broom

Sweeps snow, dirt and debris from sidewalks, driveways and warehouse floors.



Auger

Augers holes with speed and plumb-line accuracy. Bits up to 36 in. available.

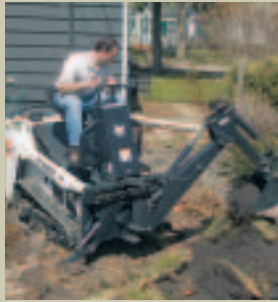

Backhoe

Excavates in hard-to-reach areas. Ideal for landscaping, nurseries, water and power lines.



Boring Unit

Install utilities under driveways, sidewalks and other obstructions with minimal ground disturbance.

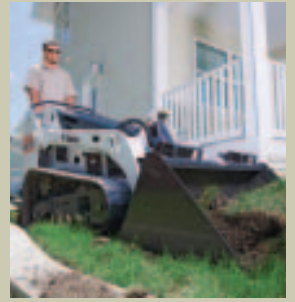

Bucket

Numerous styles and sizes. Designed to handle a wide variety of jobs and materials.



Combination Bucket

Gives you five functions in one attachment: dozing, digging, dumping, grappling, grading.



Digger

Remove rocks and stumps, dig trenches, transplant trees. Can be used for anything where a spade is used.



Hydraulic Breaker

Breaks up asphalt, concrete and rocks; smashes through walls. Exceptional power.



Grapple (Industrial, Root, Utility)

Three different grapple styles: Industrial bucket grapple for demolition and removal, root grapple sorts debris and leaves dirt behind, utility fork and grapple or bucket and grapple for light clean-up duties.



Landplane

Grades, levels, transports material, breaks up hard ground, peels sod.



Pallet Fork

Handles palletized material and long objects, such as lumber and fence posts.



Snowblower

Throw snow to clear a clean path. Rotating chute and adjustable deflector direct snow where the operator wants it to be placed.



Soil Conditioner

Smooths ruts, moves material, levels mounds and prepares soil for seed or sod.



Stump Grinder

Get into tight areas and quickly grind tree stumps into mulch.



Tiller

Digs and loosens soil, mixes compost and other materials into existing soil.



Tree Fork

With one stationary and one moveable arm, grab, lift and transport trees rocks and other oddly-shaped materials.



Trencher

Handles a wide range of jobs, including trenching close to buildings. Depths down to three feet.



Utility Blade

Use it both as a snow blade or dozer blade. Moldboard angles up to 30 degrees.



Vibratory Plow

Install flexible pipe and utility cable 6-8 inches in the ground with minimal ground disturbance.

Bobcat® Mini Track Loaders

Performance

Rated Operating Capacity
Tipping Load
Hydraulic Pump Capacity
Travel Speed

Operating Weight (with bucket)
Ground Pressure
Ground Pressure (with wide tracks)

MT52

520 lb. (236 kg)
1600 lb. (726 kg)
12 gpm (45.4 L/min.)
3.5 mph (5.6 km) forward
1.5 mph (2.3 km) reverse
2580 lb. (1170 kg)
4.7 psi
NA

MT55

550 lb. (249 kg)
1610 lb. (730 kg)
12 gpm (45.4 L/min.)
3.5 mph (5.6 km) forward
1.5 mph (2.3 km) reverse
2610 lb. (1183 kg)
4.9 psi
3.6 psi

Dimensions

Length (without bucket)
Width (with bucket)
Height
Height to Bucket Pin

72.4 in. (1839 mm)	72.4 in. (1839 mm)
36.0 in. (914 mm)	36.0 in. (914 mm)
49.1 in. (1246 mm)	49.1 in. (1246 mm)
71.3 in. (1810 mm)	71.3 in. (1810 mm)

Engine

Make/Model
Fuel/Cooling
Cylinders
HP/Displacement
Fuel Tank Capacity

D722 E3B – Tier 4 Diesel/Liquid 3 20 hp / 44.0 cu. in. 7.0 gal. (26.5 L)	D902 E3B – Tier 4 Diesel/Liquid 3 25 hp / 54.8 cu. in. 7.0 gal. (26.5 L)
--	--

Operation

Steering and Drive

Lift and Tilt

Transmission
Attachment

Direction and speed controlled by one multi-function handle.
Raise/lower and dump/rollback controlled by one lever.
Hydrostatic track drive system.
Single lever with dual direction detent.

Standard Features

Auxiliary Hydraulics Bob-Tach™ Mounting System Continuous Flow Shutoff Lever Gauges/Warning Lights Hydrostatic Drive Train Lift Arm Lockout w/Manual Bypass Lift Arm Support Lift Hook Locations	Liquid-Cooled Diesel Engine Neutral Start Interlocks Parking Brake Reverse Stop Panel Spark Arrestor Muffler Tie-down Locations Tilt Lockout Tilt Steering Track (7 in. wide)
---	---

Options/Accessories

Attachment Control Kit Catalytic Exhaust Purifier Engine Block Heater Light Kit Multi-Bar Lug Track	Non-Marking Tracks Ride-on Platform Shutdown kit Track (10 in. wide) MT55
---	--

Parts and service backup

With every Bobcat product, you get the support of a worldwide network of dealers offering industry-leading attachments, accessories and parts availability. Their factory-trained technicians are equipped to handle all your parts and service requirements, including engine and hydrostatic/hydraulic components.

Unbeatable Bobcat warranty

The best equipment carries the best warranty! The MT52 and MT55 mini track loaders come with a full one-year warranty with unlimited hours.

Operator training

An operator safety video is available.

Bobcat Mini Track Loaders – the One-Man Crew!

Just one worker can take on a variety of jobs with a Bobcat® MT52 or MT55 mini track loader. Rated operating capacities of 520 and 550 pounds make these track stars the perfect complement to your loader fleet!

Ride on 'em or walk behind 'em – they're the only mini track loaders on the market that give you a choice!

The MT52 and MT55 dig, auger, trench, move material... along with dozens of other tasks you'll think up when you're out on the worksite. It's easy to find things for the mini track loaders to do because there are so many job-matched Bobcat attachments to choose from.

Look at the size. Both models are only 35.6 inches wide and 72.4 inches long without an attachment. They go where most other machines can't – through doorways and fence gates, so you can work in close quarters indoors or outdoors. With optional 10-inch tracks, Bobcat mini track loaders are just 41.4 inches wide.

Another big plus: the rugged rubber tracks keep you going in soft, wet or muddy conditions, with minimal ground disturbance.

So grab yourself a handful of concentrated power – and get to work with a Bobcat MT52 or MT55 mini track loader!

MT52

520 LB. Rated Operating Capacity	12 GPM Hydraulic Flow	36 IN. Width (with bucket)
--	---------------------------------	---

MT55

550 LB. Rated Operating Capacity	12 GPM Hydraulic Flow	36 IN. Width (with bucket)
--	---------------------------------	---

Bobcat Attachment for these models:

- Angle Broom
- Attachment Adapter Plate
- Auger
- Backhoe
- Boring Unit
- Bucket
- Combination Bucket
- Digger
- Hydraulic Breaker
- Industrial Grapple
- Landplane
- Pallet Fork
- Root Grapple
- Snowblower
- Soil Conditioner
- Stump Grinder
- Sweeper
- Tiller
- Tree Fork
- Trencher
- Utility Blade
- Utility Fork
- Utility Grapple
- Vibratory Plow

The Bobcat Attachments Advantage: Bobcat attachments are engineered and manufactured to fit Bobcat loaders for optimum job performance, dependability and durability.

Standard MT52 and MT55 Dimensions:

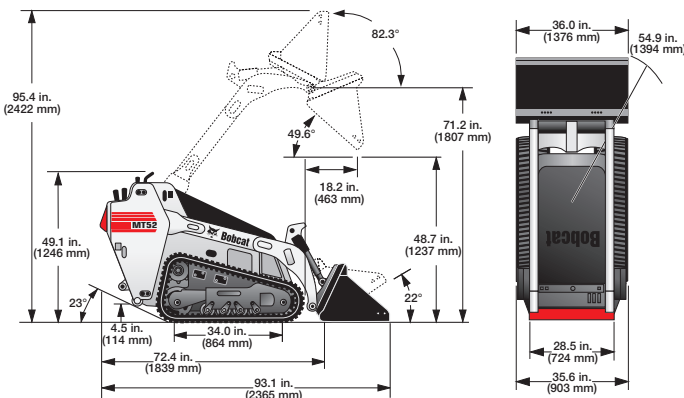

MT55 with optional 10" Track:

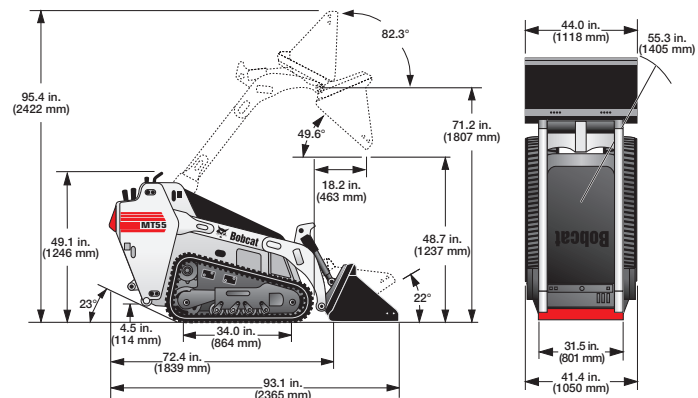

NOTE - Where applicable, dimensions are in accordance with Society of Automotive Engineers (SAE) and ISO standards. Specifications and design are subject to change without notice. Pictures of Bobcat units may show other than standard equipment. All dimensions are given for loader equipped with standard tires. All dimensions are shown in inches. Respective metric dimensions are enclosed by parentheses. Bobcat Company complies with the requirements of ISO 9001 as registered with BSI.

Bobcat® and the Bobcat logo are registered trademarks of Bobcat Company in the United States and various other countries. ©Bobcat Company. All Rights Reserved.



Bobcat Company • P.O. Box 6000 • West Fargo, ND 58078

Printed in U.S.A.

Kn-10M-413-#30545-02-F



Printed on 10% recycled paper

B-1776 (4/13)